APPROVAL SHEET

Dust Sensor Module

Model No.

DSM501(A , B)

This specification consists of 9 pages including cover.

DSM501

Dust sensor module

■ Features

PWM output
Compact size and Lightweight
Easy installation
Single power supply

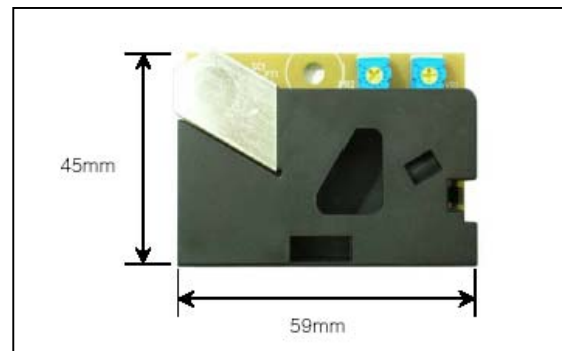

■ Application

Air cleaner or Air purifier
Air conditioner
Air quality monitor
Ventilator etc

■ Absolute maximum ratings

Parameter	Symbol	Rating	Unit
Supply voltage	Vcc	-0.3 to +7	V
Operating temperature	Topr	-10 to +65	°C
Storage temperature	Tstg	-20 to +80	°C

■ Operating supply voltage

Parameter	Symbol	Rating	Unit
Operating supply voltage	Vcc	5 ± 0.5	V

■ Electro-optical characteristics

Vcc=5V, Ta=25°C

Parameter	Symbol	Condition	Min.	Typ.	Max.	Unit
Sensitivity		> 1µm *1	-	15,000/ 283ml	-	pcs

*1 : At condition that the particle diameter is over than one micro meter.

1.0. DEVICE OVERVIEW

This specification applies to the characteristics of model No. DSM501.

The dust sensor module DSM501 is low cost, compact size for a particle density sensor.

* Quantitative particle density measurement with the principle of particle counter.

* Fine particles of which diameters are bigger than one micron could be detected with high sensitivity.

* Inside heater realizes the self-air taking.

* One control contact and two output contacts

A block diagram is illustrated in figure 1.1. The DSM501 consists of :

* Light Emitting Diode (LED) Lamp

* Detector

* Signal amplifier circuit

* Output drive circuit 1

* Output drive circuit 2

* Heater

FIGURE 1.1. BLOCK DIAGRAM

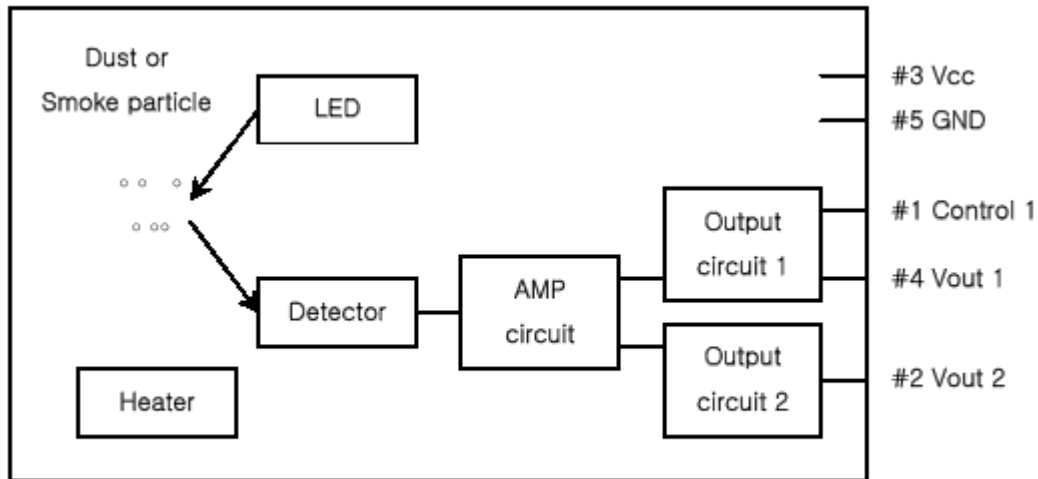

TABLE 1.1. PINOUT I/O DESCRIPTION

Pin number	Pin name	Description
#1	Control 1	Vout 1 control
#2	Vout 2	Vout 2 output
#3	Vcc	Positive power supply
#4	Vout 1	Vout 1 output
#5	GND	Ground

FIGURE 1.2. PIN ARRAY (component view)

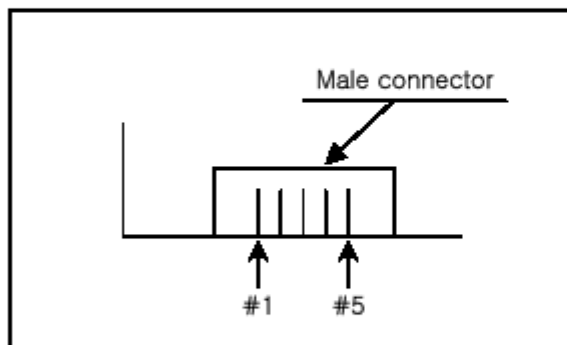

TABLE 1.2. CONNECTOR PART NUMBER

Model name	Part No.		Description	Connector's maker
DSM501A	Male	GIL-S-5P-S2L2-EF	2mm pitch	LG cable
	Female	GIL-S-5S-S2C2		
DSM501B	Male	S 5B-EH	2.5mm pitch	J.S.T.
	Female	EHR-5		

2.0. CIRCUIT DESCRIPTION

This section gives a circuit description of the external connections and components of the DSM501. The following connections and external components provide starting points for designs.

2.1. Vout 2

The Vout 2 is normal output port.

The sensitivity of Vout 2 pin is preset up. This port is detect particle which is over 1 micrometer.

2.2. Vout 1

Use this pin when sensitivity of Vout 2 is sensitive.

The sensitivity of Vout 1 is dull than Vout 2 about 2.5times. (Vout 1' s sensitivity x 2.5times = Vout 2' s sensitivity) It means size of particle is 2.5 micrometers.

Vout 1 is adjustable output. You can adjust to detecting level of particle size.

2.3. Control 1

This pin is adjustable sensitivity of Vout 1.

Use this pin when output of Vout 1 is not proper.

- How to control

Add a resistor between Control 1 pin and ground. And you can tune resistor' s value.

TABLE 2.1. RESISTOR VALUE

Resistor value	Description
open	Preset sensitivity (over 2.5 micrometer)
100K	Half sensitivity
27K	Equal sensitivity of Vout 2 (over 1 micrometer)

3.0. APPLICATION

This section provides general information on application for the DSM501.

3.1. Heater

This module has a heater (resistor) to generate heat. Heat creates updraft (upward current of air) which draw air outside of the module into the module.

3.2. Detect particle

This module is designed to detect the particle whose size is over one micrometer, which means it can detect cigarette smoke, house dust, tick, spore, pollen and mildew.

3.3. Install

The dust sensor module DSM501 should be installed vertically and kept away from any artificial current of air by fans. In case it is used for air purifier of which fan located in front or rear part, we request it to be installed at ether side of the housing, not too much deep inside of the housing. Also need to have slit around the module so that air can come inside.

In addition, please pay attention to structure and placing location of the application to avoid any adhesive particle like oil, etc. to get into the module. If it sticks to optical part,

malfunction may occur.

When inside of the module is moisturized, it does not keep its proper function. Please design the application so that moisturization of the module does not happen.

3.4. Lens

Lens needs to be cleaned depending on the condition. (once a six months) Cigarette tar on the lens should affect the sensitivity of the sensor. Wet one side of swab with water and rub the lens with it and then dry lens with the other end of swab.

4.0. ELECTRICAL CHARACTERISTIC

Vcc=5V, Ta=25°C

Parameter	Symbol	Condition	Min.	Typ.	Max.	Unit
Vout 1, 2 at high *1	Voh	No particle	4.0	4.3	-	V
Vout 1, 2 at low *2	Vol	Particle	-	0.7	1.0	V
Supply current	Icc		-	-	90	mA
Time for stabilization *3			1	-	-	minute

*1 : Vout 1 and Vout 2 are high state when not detect particle. (=clean room)

*2 : Vout 1 and 2 are go to low state when detect particle.

*3 : after the power turned on.

FIGURE 4.1. VOLTAGE VS CURRENT

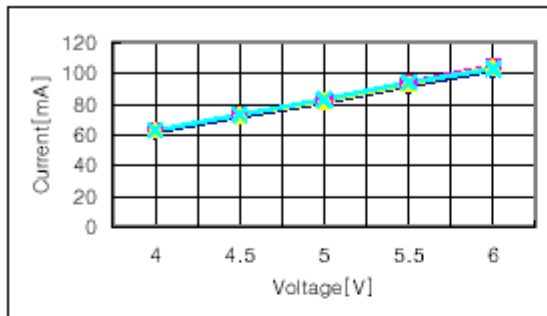
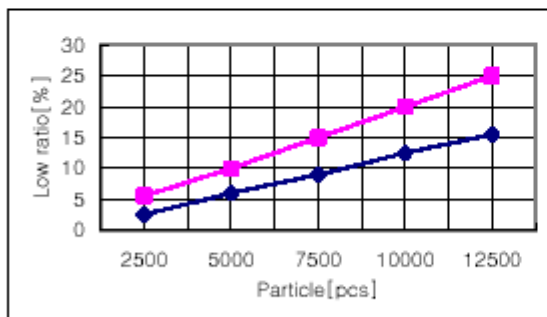

FIGURE 4.2. VOLTAGE LOW RATIO VS PARTICLE



X-axis shows number of particles and y-axis shows output characteristics. Upper curve shows upper limit output characteristics and lower one shows lower limit.

5.0. PACKAGING INFORMATION

5.1. Package marking information

Model no.	DSM501A or DSM501B
Qt'y	000 pcs

5.2. Package details

Module dimensions : W59 x H45 x D20 mm

Weight : Approx. 25g

Tray : modules of 25pcs.(5x5) per tray

Inner box : tray 5pcs per box (module 125pcs)

Outer box : inner box 4pcs per box (module 500pcs)

Dimensions : W670 x H250 x D420mm

Weight : max. 13Kg

6.0. PRODUCT IDENTIFICATION SYSTEM

To order or obtain information, e.q., on pricing or delivery, refer to the listed sales office.

DSM501	X
—	—
Model no.	A : 2mm pitch B : 2.5mm pitch

■ Notes

VR trimmer for sensitivity adjustment is set up at shipping from Apollo. Please don't touch the VR trimmer.

Please don't disassemble the device. Even if the device is reassembled, it may not satisfy the specification.

There is a case that it does not detect the dust density correctly, since the dust adhered to the outside of the lens. When the dust is adhered, please consider the maintenance such as vacuuming or blowing off the dust by air.

Please don't use this device for an emergency application or fire alarm application.

This publication is the proprietary product of Apollo and is copyrighted, with all rights reserved. Under the copyright laws, no part of this publication may be reproduced or transmitted in any form or by any means, electronic or mechanical, for any purpose, in whole or in part, without the express written permission of Apollo. Express written permission is also required before a third party may make any use of this publication.

7.0. RELIABILITY

The reliability of products shall satisfy items listed below.

Table 7.1. TEST ITEMS

No	Test items	Test condition	Requirement
1	High temperature and high humidity storage	+80°C, 90%RH, 48hours	
2	High temperature and high humidity operation	+65°C, 90%RH, 48hours	
3	Low temperature storage	-20°C, 48hours	
4	Low temperature operation	-10°C, 48hours	
5	Impact	To drop module 3times at random onto a hard wooden plate from 1 meter above high	No breakage, no cracks.

*1. After test, measurement shall be done after leaving under the normal temperature and the normal humidity for 2hours. And there should be no dew.

8.0. OUTGOING INSPECTION

8.1. Inspection lot

Inspection shall be carried out per each delivery lot.

8.2. Inspection item

Refer to the attached spec sheet, page 9.

The measured voltage values are marked in spec sheet.

8.3. Inspection method

Table 8.1. TEST METHOD

No	Items	Method	Requirement
1	Appearance	Visual	Non rough dirt Non loose parts
2	Ampere and voltages	Measured ampere and output voltage of each test points	Spec in

